

Steinadler Pro

PRODUCT MANUALS

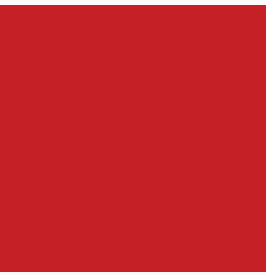



01

|

INTRODUCTION



Preface

- Thank you for choosing RJ Tech Steinadler Pro! We wish you a safe and enjoyable riding experience.
- Please carefully review the product manual before operating your vehicle. This manual provides essential information, including an overview of the product, safe riding practices, operating guidelines, troubleshooting, and maintenance instructions.
- This manual reflects the most up-to-date information available at the time of printing. As the product undergoes continuous improvement, minor discrepancies may exist between your vehicle and the contents of this manual. In such cases, please refer to the actual product for accuracy.
- This manual will be updated with each product iteration. To access the latest version, please contact us or an authorized dealer.
- Using the vehicle for illegal activities or making unauthorized modifications is strictly prohibited. Always comply with local laws and regulations, and refrain from operating the vehicle on unauthorized roads or in restricted environments.
- No part of this manual may be copied, reproduced, extracted, adapted, translated, or otherwise used without the express written permission of RJ Tech Limited.
- RJ Tech Limited reserves all rights.

Packing List

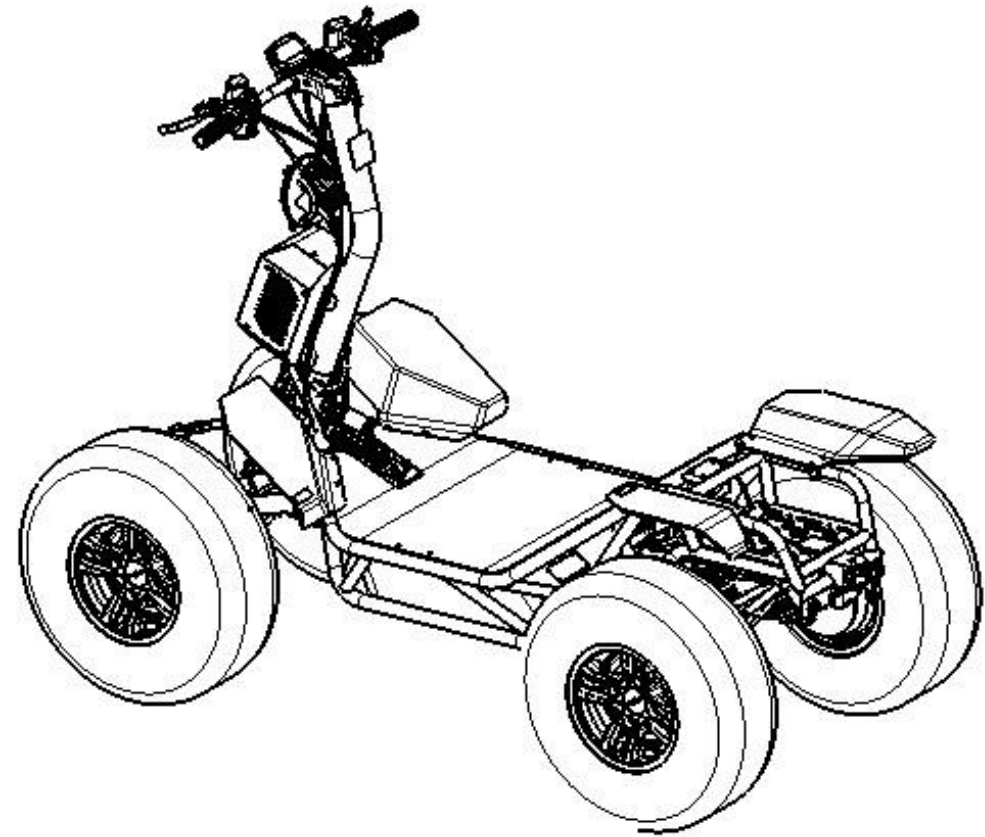

Main Vehicle x 1



Product Manual x 1



Aftersales Term & Condition x 1

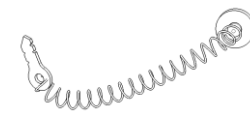

Safety key x 1

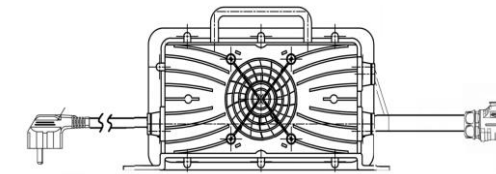

Charger Set x 1

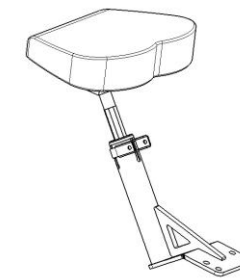

Seat x 1

Vehicle key x2

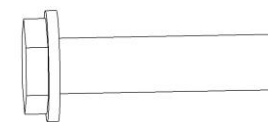

Seat mounting bolts x 4



02

SAFETY DRIVING



2.1 Owner's Liability

As the owner of the Steinadler Pro, it is your responsibility to operate the vehicle safely and properly. Each driver must familiarize themselves with the following requirements before riding:

- **Driver Qualification:** Drivers should legally obtain appropriate training and relevant certificates for safe and correct riding techniques, in accordance with the laws and regulations of the location where the vehicle will be operated.
- **Compliance with Traffic Regulations:** Always observe local traffic safety regulations when driving this vehicle.
- **Adherence to Safety and Maintenance Instructions:** Follow the driving safety guidelines and maintenance requirements provided in this user manual.
- **Proper Use:** The vehicle is used responsibly and strictly for lawful purposes. Unauthorized modifications or illegal activities involving the vehicle are prohibited.
- **Regular Maintenance:** The vehicle is regularly inspected and maintained to ensure it remains in safe working condition.
- **Driver Awareness:** All drivers are adequately trained and fully aware of the operational and safety requirements of the vehicle.

Failure to adhere to these responsibilities may result in legal consequences or void the product warranty. RJ Tech Limited disclaims any liability for damages or injuries arising from misuse, improper maintenance, or failure to comply with safety guidelines.

2.2 Driving Position Requirements

To ensure safe and proper operation of the Steinadler Pro, drivers must adhere to the following driving position requirements:

- **Proper Seating:** Always sit securely on the designated driver's seat with your center of gravity distributed between the seat cushion and your feet. Do not rely entirely on the seat cushion for support.
- **Handlebar Grip:** Hold the handlebars firmly with both hands at all times. Never release the handlebars while operating the vehicle.
- **Knee and Body Position:** Maintain a slight bend in your knees when standing while driving to help absorb shocks and maintain balance. Keep your body's center of gravity positioned between your legs for optimal stability.
- **Foot Placement:** Position your feet firmly on the board. This ensures better control and balance during operation.
- **Cornering Technique:** When navigating turns, please keep your center of gravity low and follow the angle of the corner by shifting your body weight to the inside of the turn.
- **Upright Posture:** Sit upright with your back straight during normal operation to maintain control and reduce fatigue. Avoid leaning excessively in any direction unless adjusting for turns or terrain.
- **Visibility and Focus:** Ensure an unobstructed view of the road ahead and remain focused on the terrain. Avoid distractions that may hinder your reaction time.
- **Protective Gear:** Always wear appropriate protective equipment, including a certified helmet, gloves, and sturdy footwear. Additional protective gear, such as knee and elbow pads, is recommended for enhanced safety.
- **Passenger Guidelines:** Ensure passengers are seated securely and follow safety protocols. Never exceed the recommended number of passengers or weight capacity.

By following these driving position requirements, drivers can enhance safety, stability, and control during operation. Failure to comply with these guidelines may increase the risk of accidents and injuries.

2.3 Driver Requirements

- Ensure that the driver is at least 16 years old and free from any heart conditions or other medical.
- Confirm that the driver has not consumed alcohol, stimulants, hallucinogens, or any substances that may impair judgment.
- Verify that the driver is not recovering from significant physical injuries, such as broken bones or muscle strains.
- Avoid driving while fatigued, as tiredness and negligence can impair decision-making and reaction times.
- New drivers should maintain a moderate speed, particularly on rough road surfaces or when navigating turns.

2.4 Driver Protection Requirements

As a vehicle owner, always wear protective equipment that meets national safety certification standards for riding. Proper gear is essential to safeguard yourself against potential hazards from weather and road conditions. Ensure you are equipped with the following:

- ① **Helmet:** A certified helmet to protect your head.
- ② **Goggles:** Protective goggles to shield your eyes from dust, debris, and weather elements.
- ③ **Gloves:** Durable gloves for hand protection and improved grip on the handlebars.
- ④ **Long-Sleeve or Cycling Jersey:** To provide coverage and protection against scrapes and exposure.
- ⑤ **Long Pants:** For leg protection from impacts and environmental factors.
- ⑥ **Boots:** Sturdy boots that fully cover your feet and provide ankle support for added safety.

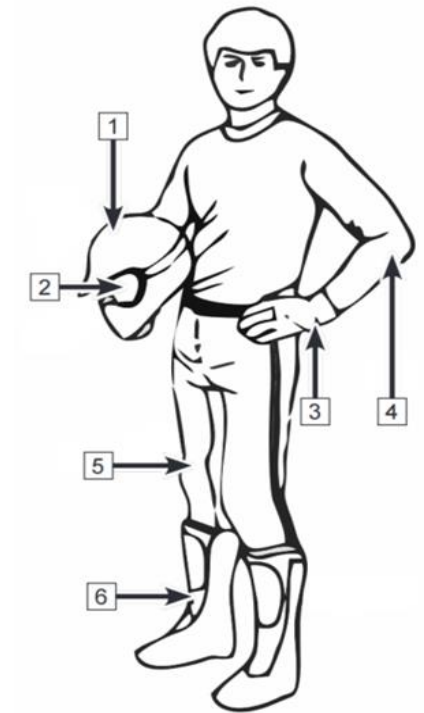



03

**PRODUCT
INTRODUCTION**



3.1 Product Parameters

The main components of this vehicle consist of the main vehicle (①), range extender (②), and trailer (③). The range extender and trailer can be purchased or equipped based on individual needs.

The key specifications are as follows:

- Vehicle Model: Steinadler Pro
- Dimensions of Main Vehicle (L x W x H): 1820mm x 775mm x 1245mm
- Main Vehicle Weight: 200kg
- Main Vehicle Load Capacity: 100kg
- Maximum Speed of Main Vehicle: 50 km/h
- Main Vehicle Range: 100 km
- Max Motor Power: 5 kW x 4 (Maximum)
- Environmental Operating Range: -20°C to +45°C

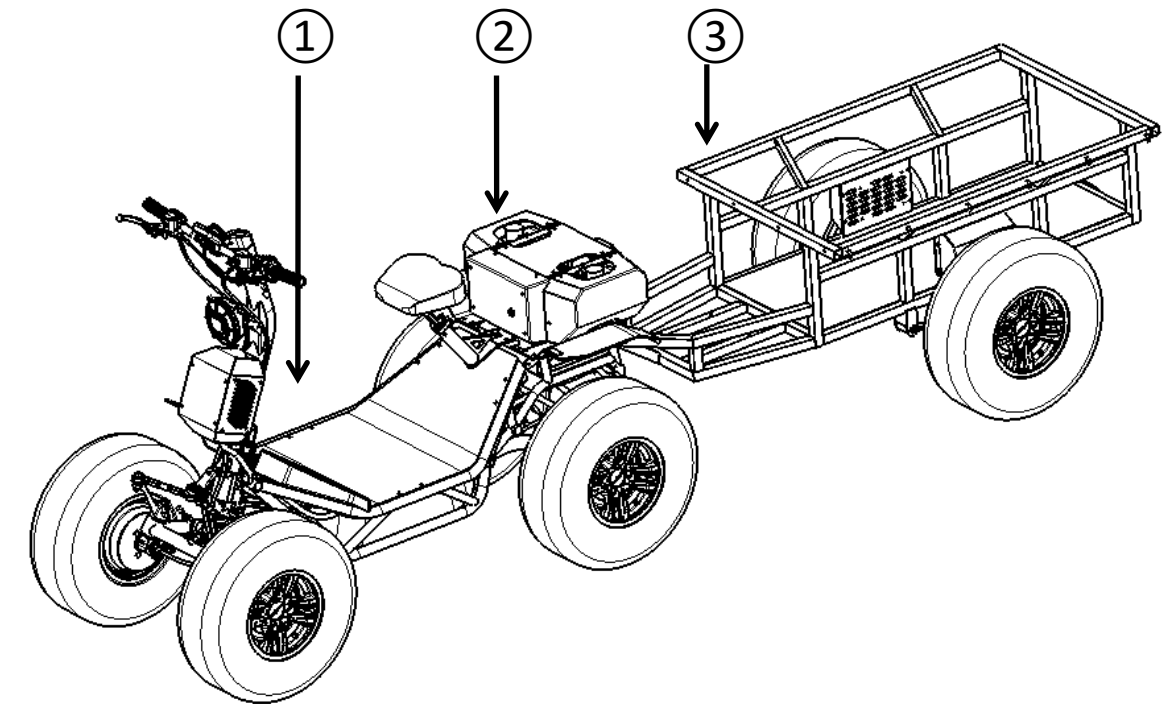

3.2 Product Code

The **vehicle identification information** is provided in two locations:

- ① **VIN** (Vehicle Identification Number)
- ② **Product Nameplate** (Displays information related to the vehicle's production)

Note: Do not remove or damage the identification information, as doing so may affect the warranty coverage.

You may be required to provide the vehicle's identification information in the following situations:

- For registration as required by local laws and regulations
- When ordering replacement parts
- For product warranty claims or replacements
- Please refer to the locations indicated below for more detailed information.

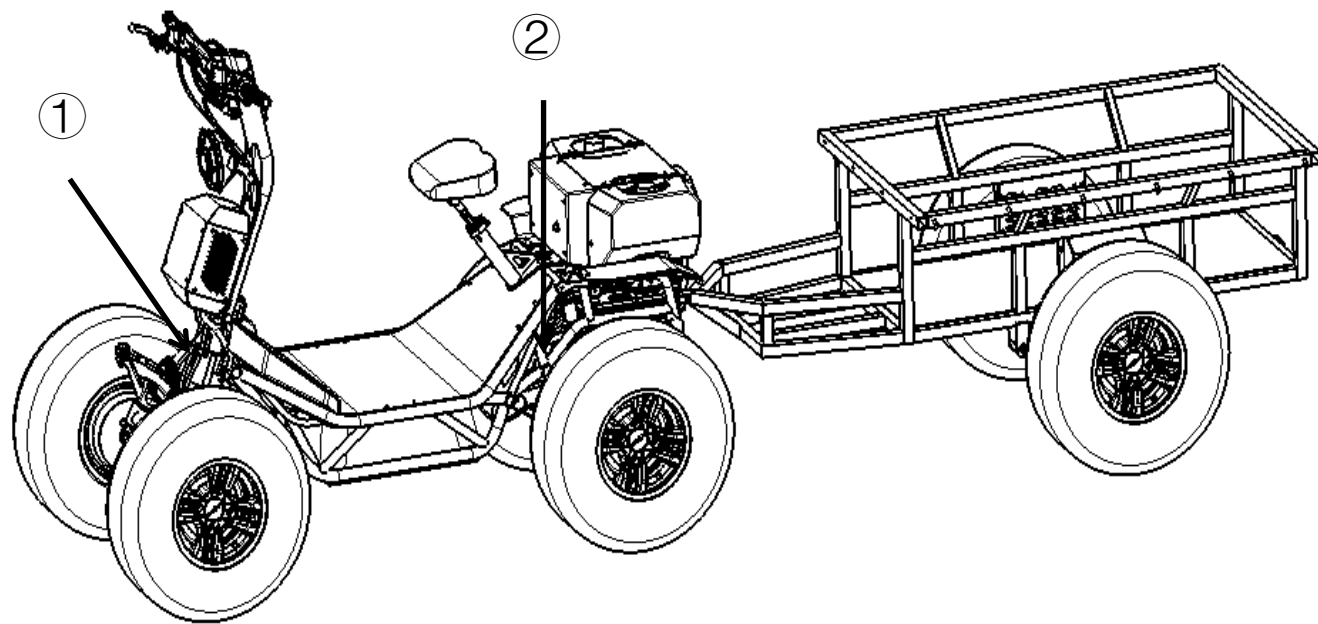

Jiangsu YINGUAN Intelligence Technology Co.,LTD.		CE	→ ① Company Name
		RoHS	→ ② Certification Information
ATV			
Model	Steinadler	→	③ Product Information
Battery	69V64Ah	→	④ Battery Information
Horsepower	19hp	→	⑤ Vehicle power
Series No.	MDBC000L1V01240320XXX	→	⑥ Product serial number
Dry Weight	200kg	→	⑦ Net weight of the main vehicle
Payload Capacity	100kg	→	⑧ Main vehicle load-bearing
Date	Mar 2024	→	⑨ Vehicle production date
Made in China.			→ ⑩ production site



04

**DRIVING
INSTRUCTIONS**



4.1 Pre-driving Preparation

4.1.1 Adjust the Main Vehicle

Using the folding mechanism, adjust the vehicle's column from the folded position to the upright position. Tighten bolt ① to ensure the folding mechanism latch is secure, and verify that the handle is stable and not loose, as shown in the figure.

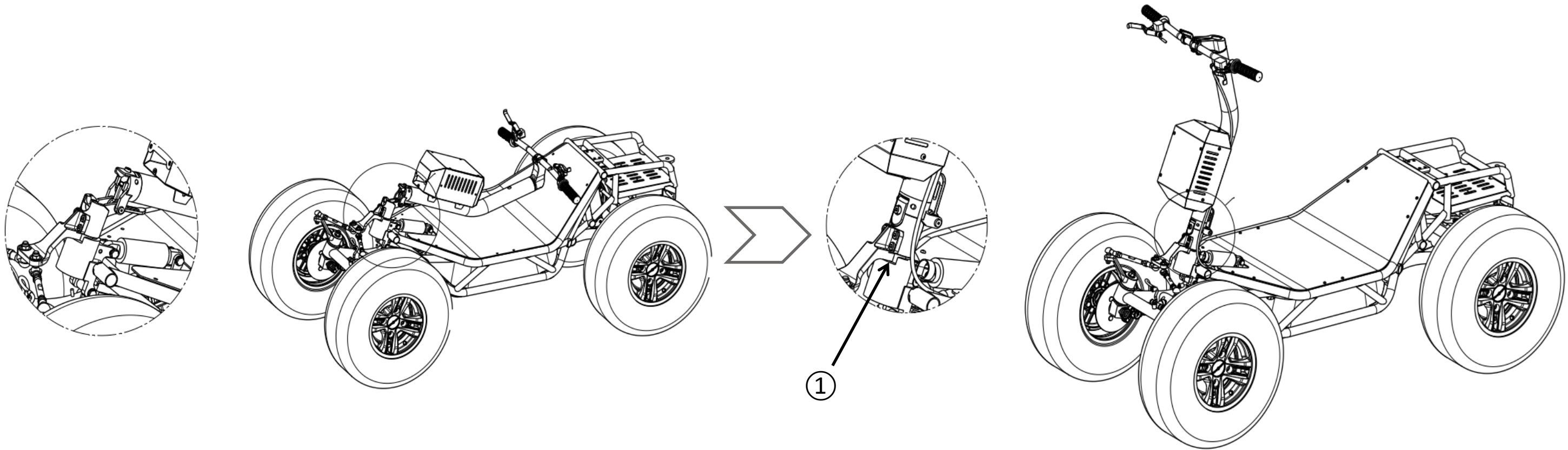

4.1 Pre-driving Preparation

4.1.2 Pre-driving Inspection

Check List	Item
Vehicle Harness	Check the wiring harness for interference with other mechanisms, breaks, breaks, deformations, and organize or repair as necessary.
Main Vehicle	Check body connections for breaks, visible deformation, loose screws, etc. Repair or stop driving if necessary.
Battery Power	Check the remaining charge of the power battery and recharge it if necessary.
Steering Handle	Check that it operates smoothly
Throttle	Check that it operates smoothly
Front/Rear Brake	Check brake fluid level and brake pad wear
Instrument panel/Lights/Switches	Check the instrument panel, lights and switches for proper operation.
Wheels & Tires	Check for tears, tire condition and tread pressure and replace or inflate as necessary.

4.2 DRIVING INSTRUCTION

4.2.1 Left Handle Switch

① Rear wheel brake

The rear wheel brake is used to apply braking to the rear wheels, helping to lower the center of gravity during braking and stabilize both the vehicle and the driver's posture. To engage the rear wheel parking brake, push down on the small adjustable handle to lock the brake in place.

② Reverse switch

To activate reverse mode, push the vehicle upward. To return to forward mode, push it downward. The vehicle is initially set to forward mode.

③ Driving mode Switch

The switch on the left side controls the vehicle's automatic steering function, which is only active when the vehicle is stationary.

Switch to the center to engage 2WD mode.

Switch to the right to engage 4WD mode.

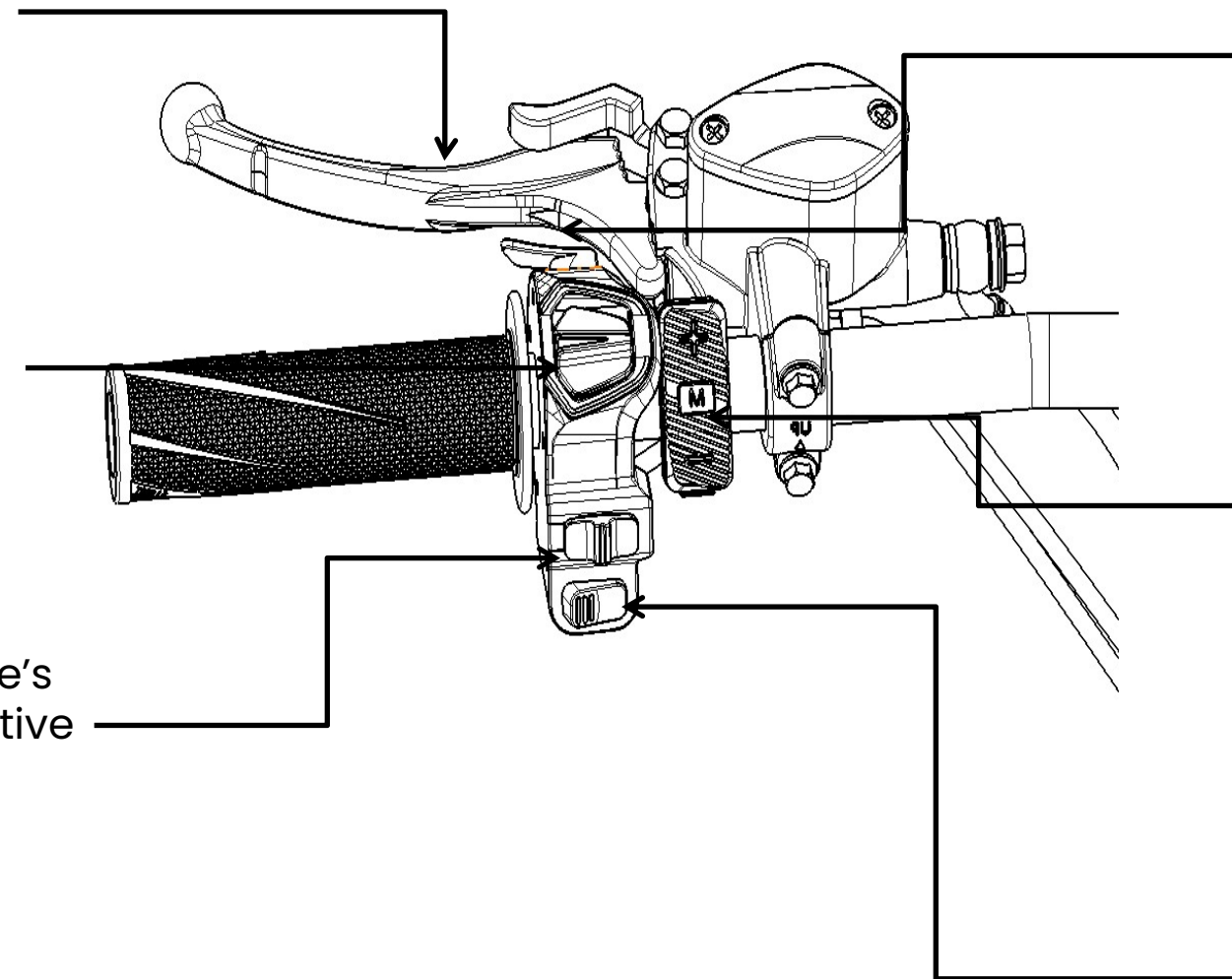

④ Horn switch

Press and hold this switch to activate the vehicle's horn. Release the switch to stop the horn.

⑤ Integrated speed limit switch

By pressing the "+" or "-" buttons on the switch, you can control the vehicle's gear. The higher the gear, the greater the input power in a given time, resulting in more challenging driving conditions. Gear 3 is set to the highest gear. For beginners, it is recommended to use gear 1 for easier control and a smoother experience.

⑥ Light switch

Press to turn on the headlights and taillights, press again to turn off the headlights and taillights

4.2 DRIVING INSTRUCTION

4.2.2 Right Handle Switch

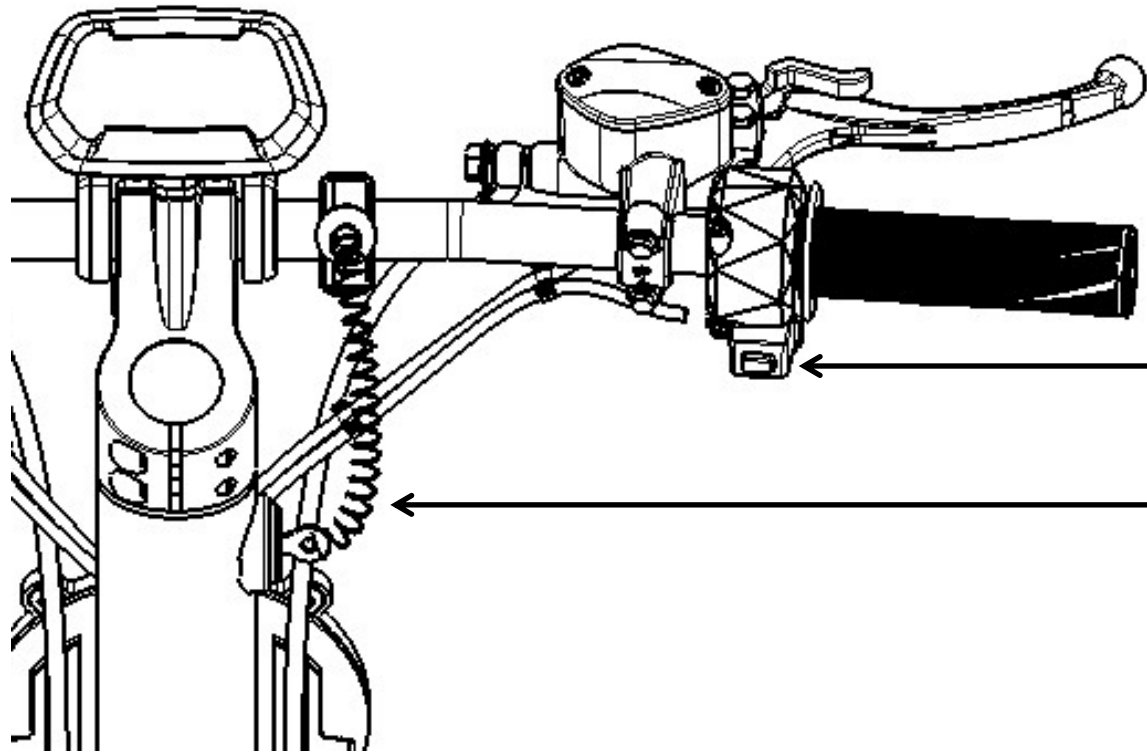

① **Front wheel brake**

To engage the front wheel parking brake, push down on the small adjustable handle to lock the brake in place.

② **Throttle**



Once the vehicle is powered on, use the throttle to control the vehicle's power output by rotating it. The larger the rotation angle, the greater the power delivered to the vehicle.

③ **Horn switch**

Press and hold the switch to activate the vehicle's horn. Release the switch to turn off the horn.

④ **Safety Key**

Disconnect the safety rope and power off the vehicle.

4.2 DRIVING INSTRUCTION

4.2.3 Power-on Switch

Power-On: Turn the key to the ON position and wait for about 5 seconds until the dashboard displays all the information.

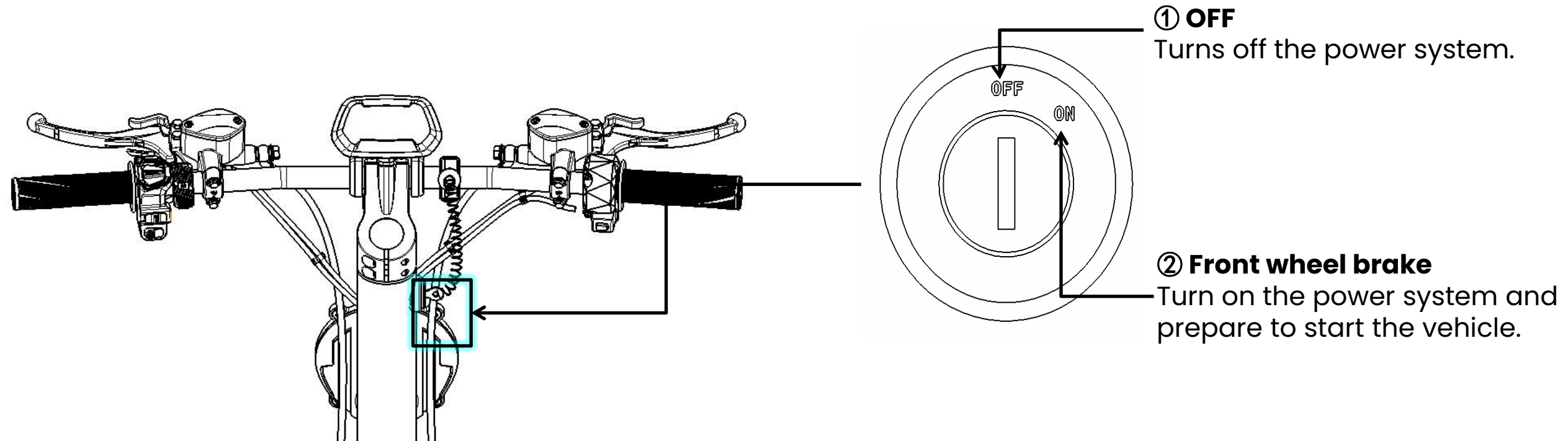

4.2 DRIVING INSTRUCTION

4.2.4 Instrument Panel Description

① **Battery power**

Remaining battery power (SOC%) of the vehicle

② **Speed**

Current speed of the vehicle

③ **Mileage**

Total vehicle mileage



④ **Power**

The magnitude of the current instantaneous power input to the vehicle

⑤ **Gear**

Power and speed limiting gear (the higher the gear, the higher the power output per unit of time, limited to the forward state)

4.2 DRIVING INSTRUCTION

Seat Installation

- The seat is secured to the main vehicle using 4 bolts ①.
- The seat height can be adjusted based on the driver's height and driving experience ②.

Attention

- Bolt Torque: 40 ± 5 Nm.
- Only seats supplied by our company are compatible with the main vehicle. Using other seats may result in safety risks, and the user will be responsible for any consequences.
- When driving with the seat installed, always drive smoothly, reduce speed, and avoid high speeds to minimize the risk of rollover.
- Regularly check the fastening of the seat components and perform necessary maintenance.
- If the seat is damaged or becomes unusable, please contact your local service center promptly.

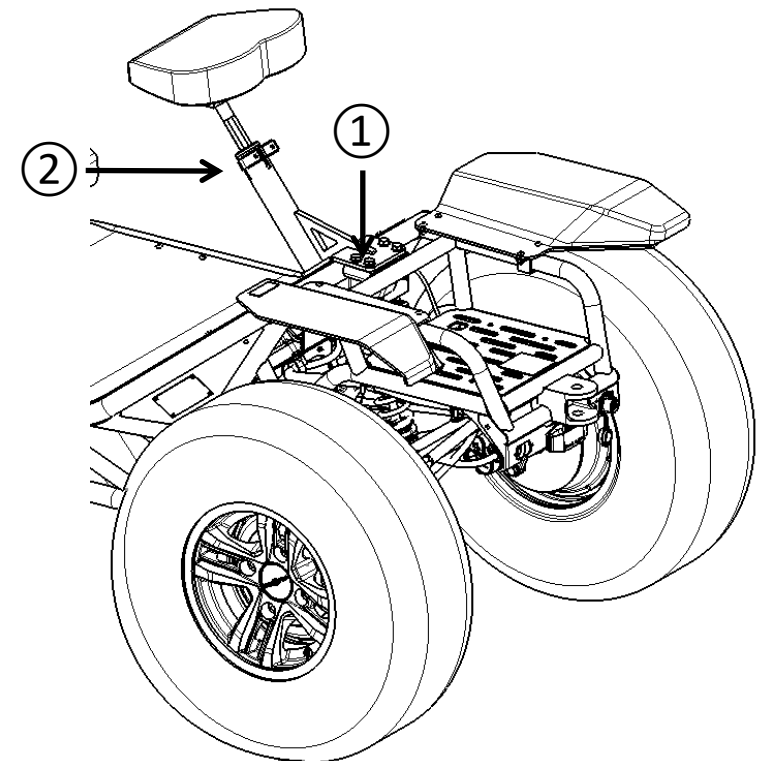

4.2 DRIVING INSTRUCTION

4.2.6 Charging Instructions

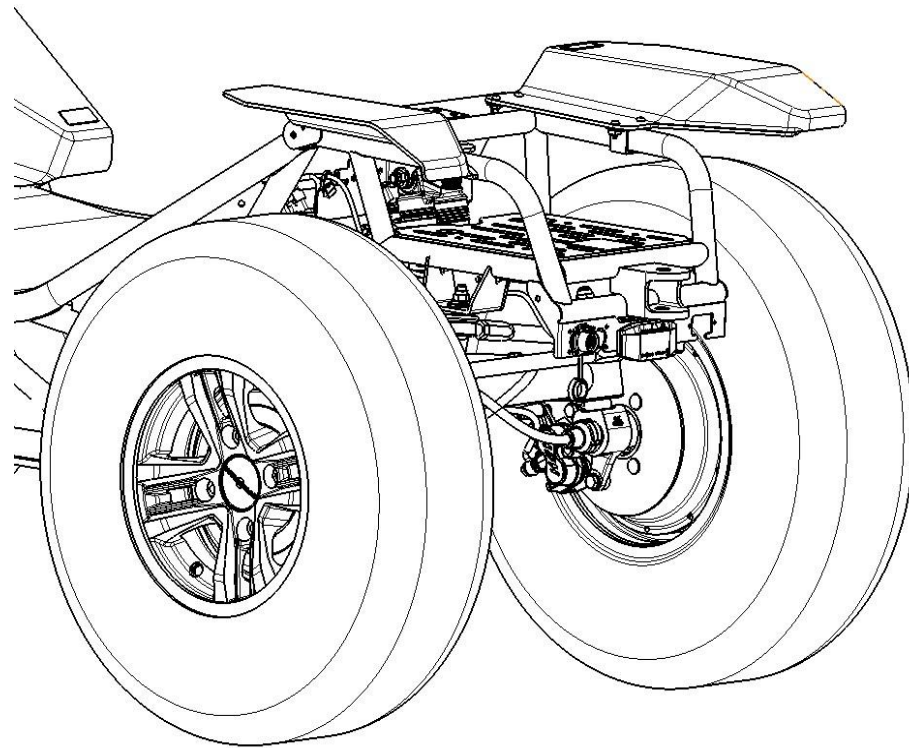

① **Range Extender Charging Port**
For range extender charging

② **Tail light**

③ **Charger charging port**
The charging port is designed for direct connection with the charger. Please use the charger provided with the vehicle and avoid replacing it with any other charger.

Note: All electrical connectors must be covered with protective caps when not in use. This helps prevent dust and water ingress, which could cause short circuits and interfere with the vehicle's normal operation.

4.2 DRIVING INSTRUCTION

4.2.7 Charging Instructions - Charger

Charger Status Indicators:

- Red and Green Light Flashing: Charger is in standby mode.
- Red Light Constant On: Charger is in the process of charging.
- Green Light Constant On: Charging is complete, and the battery is full.
- Red Light Flashing: Indicates an abnormal situation or error with the charging process.

Charger Specifications:

- Rated Input Voltage: **220V AC ± 15%**
- Rated Input Current: **≤ 9A**
- Maximum Output Voltage: 90V DC
- Maximum Output Current: 18A DC

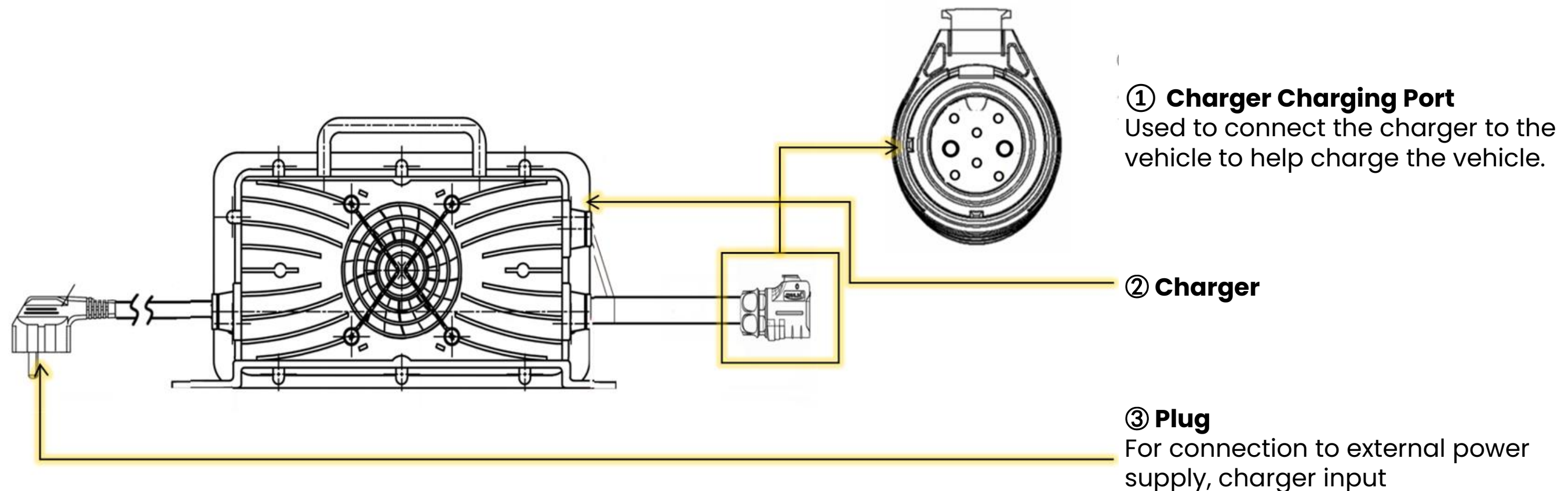

4.2 DRIVING INSTRUCTION

4.2.8 Charging Precautions

- When charging, always plug the vehicle into the charger first, then connect the power plug to the socket.
- When disconnecting, unplug the power plug first, then disconnect the vehicle.
- Do not recharge the battery once charging is complete.
- The charger must be used exclusively for this vehicle. Do not lend or cross-use the charger to prevent potential damage.
- The charger should not be immersed in water. If the plug or charger body becomes wet, stop using it immediately.
- Keep the charger away from explosive gases, flames, or sparks.
- Ensure the charger is used in a well-ventilated area. Avoid placing it on soft surfaces like sofas or other flammable materials, as it generates heat during operation.
- The charger uses fan cooling, and the sound of airflow from the fan is normal.
- If the charger, power socket, or power cord is damaged or deformed, stop using it immediately and have it replaced by a professional.
- Ensure good ventilation around the vehicle and avoid charging in areas at risk of thunderstorms.
- Do not overload power outlets by plugging in too many devices.
- When plugging or unplugging the charger, do not pull on the cables directly.
- If the charger shell becomes excessively hot or there are any other issues that you cannot resolve, stop charging immediately and consult a professional for servicing.



05

**MAINTENANCE
& REPAIR**



5.1 Vehicle Maintenance Suggestion

To ensure the safety and performance of your cruising vehicle, routine maintenance needs to follow the manufacturer's approved maintenance schedule (see Table KM below) to maximize performance and product longevity

Item	Suggested Time (Weeks)	2	3	6	12	26	52
	Suggested Distance (kilometers)	100	500	1000	2500	5000	10,000
Driving	Check parts for looseness	✓		✓	✓		
	Checking steering alignment	✓		✓	✓		
	Check for loose parts in front wheel hub bearings	✓		✓	✓		
Front Suspensions	Visual inspection of rubber bushing	✓	✓				
	Visually inspect rubber bushing bolts	✓	✓				
	Check front suspension for loose parts	✓	✓				
	Replacing the plain bearings in the front suspension			✓			
Rear Suspension	Visual inspection of rubber bushing	✓	✓				
	Visual inspection of rubber bushing bolts	✓	✓				
	Replacing the plain bearings in the rear suspension			✓			
Electronic component	Visual inspection: bases, connections, cleaning	✓	✓				
	Check that the wiring is intact and not cracked or scratched	✓	✓				
Battery	Visual inspection: base, joint cleanliness, clips		✓				
	Battery case inspection	✓	✓				
	Battery Warranty						✓
Brakes	Visual inspection: friction pads, brake fluid					✓	
	Replace friction pads, increase brake fluid					✓	

Maintenance Instructions:

- Power-off Requirement:** All maintenance work must be carried out with the power switch in the OFF position.
- Vehicle Positioning:** Maintenance should only be performed once the vehicle has been safely lifted using a jack or lift, ensuring that the wheels are not in contact with the ground.
- Authorized Service Centers:** Maintenance must be conducted at an authorized service center, except for the specific procedures outlined in the table below.
- Malfunction Handling:** If any malfunction is detected during maintenance, it must be addressed and repaired at an authorized service center.

5.3 Wear Parts Maintenance

No	Item	Parts
1	Sump	Suspended rubber
2	Sump	Suspended plain bearings
3	Sump	Friction disk
4	Sump	Shock absorber rubber
5	Sump	Copper bushing of swing arm
6	Sump	Steering bearings
7	Sump	Main pin bearings

Maintenance Instructions:

- **Wear and Tear Components:** Some vehicle parts are subject to wear and tear. During the warranty period, if non-user-related damage or product quality issues occur, the user should refrain from performing self-repairs or any other modifications. Instead, please contact the authorized service center for maintenance.
- **Post-Warranty Maintenance:** After the warranty period, if the trailer requires parts replacement or repair, the user may perform basic maintenance using the provided tools such as wrenches and screwdrivers. Any repairs must ensure that fasteners are tightened to the proper torque specifications. It is also important to check the trailer's functionality after completing repairs.
- **Limitation of Liability:** The manufacturer and distributor are not responsible for any issues resulting from personal maintenance activities performed outside of the warranty period.
- **Major Repairs:** For significant repairs, it is recommended to contact an authorized service center to ensure proper handling and repair.

5.4 Vehicle Storage Instructions

- **Storage Environment:** Ensure that the vehicle is stored in a dry, well-ventilated area to prevent moisture buildup and ensure optimal condition.
- **Battery Care:** The vehicle's power battery should be fully charged before storage. For long-term storage, it is recommended to recharge the battery every 3 months to maintain its health.
- **Tire Maintenance:** Check the air pressure in the vehicle's tires using the air pressure gauge (refer to the "Pre-driving Check" section) and adjust the tire pressure to the appropriate level for storage conditions.
- **Outdoor Storage:** If the vehicle is stored outdoors, it is advisable to use a full-body cover to protect it from the elements.
- **Optimal Storage Temperature:** The recommended temperature range for long-term storage is between -20°C and $+45^{\circ}\text{C}$.
- **Battery Disconnect:** For extended storage periods, disconnect the power battery and ensure it is stored with a charge of approximately 50% to prevent depletion.

5.5 Vehicle Transportation Instructions

- **Transporting the Vehicle:** When transporting your vehicle, always use a trailer or a flatbed truck equipped with a loading platform, lifting platform, and vehicle tie-downs. Before loading, ensure the front wheels are aligned straight ahead relative to the trailer or truck. Secure the vehicle with strong, non-elastic straps or crossbars, fastening them to fixed parts such as the frame.
- **Handlebar Care:** When folding the handlebars for transport, take care not to damage any handlebar accessories, including switches and gauges.
- **Protection from Weather:** If transporting the vehicle in rainy conditions, ensure that the vehicle is properly covered and shielded from exposure to rain.
- **Brake System Adjustment:** After folding the handlebars, press the front and rear brakes several times to release any excess air from the braking system.
- **Post-Transport Checks:** Upon setting up the vehicle for operation after transport, ensure the handlebar folding mechanism is securely tightened. Also, check and adjust the tire air pressure to the specified range.
- **Caution:** Improper towing of the vehicle may cause damage to the power system or other components. If manual handling of the vehicle is necessary, always wear protective gloves to avoid injury. Be cautious of pinch points, especially near the wheel hubs and brakes, during handling.

5.6 Vehicle Cleaning

- Turn off the power before cleaning the vehicle. Use a soft cloth to remove dust, dirt, and mud.
- For cleaning, use a soft cloth or a slightly damp sponge to wipe down the Cruise vehicle.
- Wipe the vehicle with a soft, damp cloth moistened with water.
- Dry the vehicle with a soft, dry cloth after cleaning.

Note:

- The vehicle can be cleaned directly with a water gun, except for electrical accessories and certain ports.

Caution:

- Avoid water exposure to the trailer connector and steering handlebar electrical components.
- Do not allow water to come into contact with the motor outlets, as it may affect the warranty.
- Only use water for cleaning.
- Do not use cleaning agents or chemicals, as they may cause corrosion or discoloration.

5.7 Environmental Requirements

5.7.1 Waste Recycling

- Place motor oil and other toxic wastes in approved containers and take them to a certified recycling center.
- Contact your local public affairs or environmental services office for information on nearby recycling centers and guidelines on how to dispose of non-recyclable waste.
- Do not dispose of used transmission oil in a garbage can, down the drain, or on the ground.
- Used motor oil, gasoline, and coolant contain toxic substances that can harm individuals and pollute vital resources such as drinking water, lakes, rivers, and the ocean.

5.7.2 Power Battery Disposal

- If you are unsure about how to properly dispose of your vehicle's battery, contact your local public affairs or environmental protection services office. Alternatively, consult your local authorized dealer for guidance.

Note: While enjoying the experience of driving, we encourage you to be mindful of environmental protection requirements. Together, we can help protect the Earth.



06

Troubleshooting



6.1 Troubleshooting Repair Instructions

The following table provides troubleshooting repair instructions for vehicle important information. If the displayed or manifested faults are not reflected in the table below, please contact your authorized service center for processing.

#	Problems	Reasons	Repair
1	Cruise vehicle won't run when throttle is rotated	Power-on/off switch set to OFF Uncharged power battery	Turn power-up switch to ON Charge the power battery
2	Bumps in the ride	Battery depletion	Charge the power battery
3	Decreased power performance when driving under heavy loads	Drive overheating	Turn off the vehicle. Allow vehicle to cool for 10 minutes
4	Unstable driving	leaky tire Incorrect tire pressure	Repair tire Inflate tires to reference pressure
5	Vehicles not slow down as much as usual when you let off the throttle	VCU failure Throttle stuck in FULL mode	Contact service centers Contact service centers
6	Brake noise during driving	Debris trapped between brake pads and rotor	Remove debris
7	Vehicles can't back up	Security mechanism activated	Let off the gas, stop in place and retry
8	lights don't work	Malfunction of a switch Electrical system failure	Turn off and retry Check wiring integrity
9	Small brake force, increased braking distance	Air in brake lines or worn friction pads	Brake system bleed or replace friction pads

Handling Instructions:

- Separation of the standing platform is prohibited. Any disassembly of the platform should only be performed at an authorized service center.
- Disassembly of the switch is also prohibited.
- Any unauthorized operation not specified in the table below will void the warranty.
- For issues that cannot be addressed by the customer, please contact an authorized service center for assistance.



07

APPENDIX



Appendix I–Screw Torque Table

#	Position	Screw/Nut Specifications	Recommended torque Nm
1	Front & rear suspension rubber	M10	70±5
2	Front and rear suspension arms & frame	M12	70±5
3	Front and rear shock absorber ends	M10	70±5
4	Front suspension rod ends	M10	70±5
5	Turnbuckle	M8	40±5
6	Steering rod adjustment	M12	70±5
7	Steering tie rod ball pins	M10	70±5
8	Steering rocker arm	M12	110±5
9	Motor locking	M24	120±10
10	Wheel nut	M10	70±5
11	Brake caliper	M8	40±5

Appendix II-Handlebar Steering

Since the design of this vehicle differs from that of a motorcycle, it requires significantly more effort for in-situ steering while stalled. This is a normal phenomenon. (The handlebar's left and right steering limit angle is approximately 32°. During the steering check, simply ensure that the steering does not become stuck or misaligned, as this is considered normal operation.)

Although the handlebar steering mechanism of this vehicle is similar to that of a motorcycle, the driving dynamics are quite different, especially when steering the vehicle.

If you need to steer the vehicle while driving, please follow these guidelines:

- Keep the vehicle speed as low as possible.
- Stabilize your body by lowering your center of gravity to improve your driving position.
- When steering, shift your center of gravity in alignment with the curve and lower it toward the inside of the turn.

Please adhere to these requirements to avoid loss of control and reduce the risk of a dangerous accident.

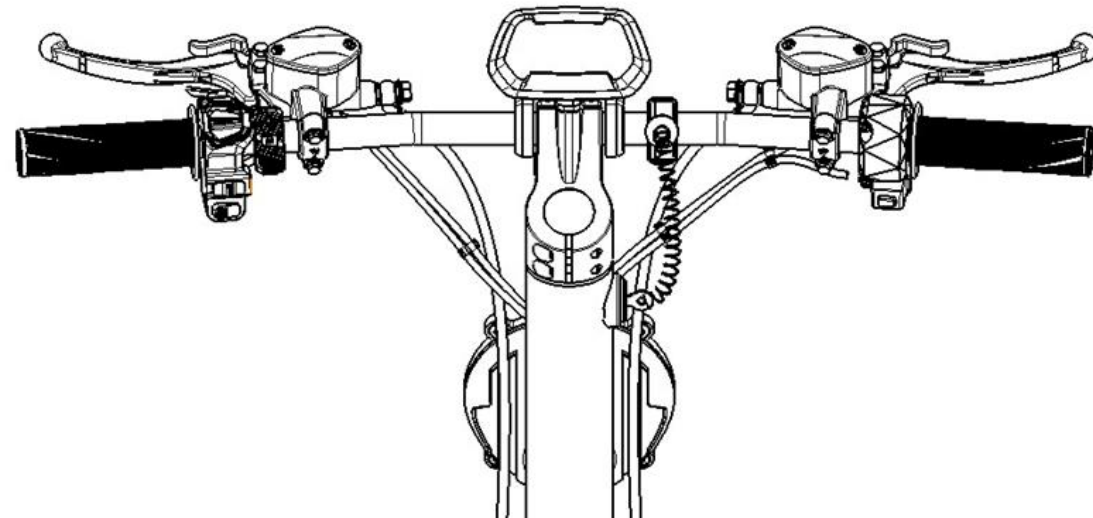

Appendix III-Brake Inspection

Brake Fluid Check

- Turn the steering handle and verify that the brake fluid level is above the lower level mark when it aligns with the marked line.
- If the brake fluid level is below the mark, add brake fluid until it reaches the indicated level.
- If the free travel of the brake lever exceeds the specified limit, contact your local authorized service center for further inspection and service.
- Recommended Brake Fluid: **DOT 3**

Brake Pad Inspection

- Refer to section 6.1 Troubleshooting and Repair Instructions for guidelines on brake pad replacement.

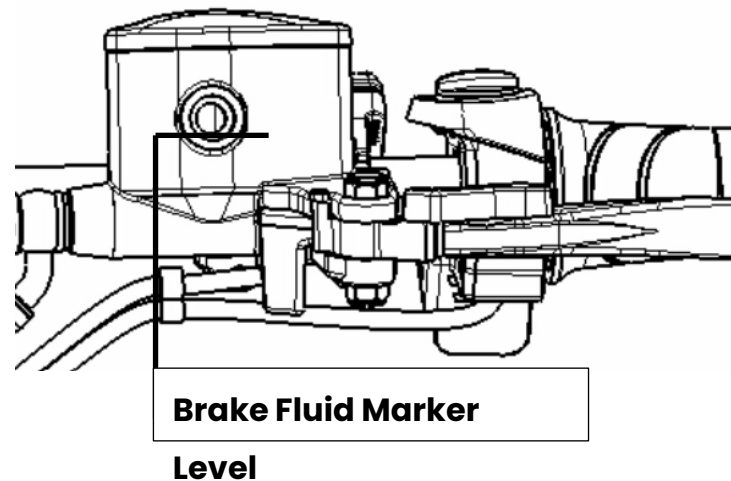

Appendix IV–Tire Pressure Gauges

The following are recommended pressures only, and the driver may make minor modifications to the tire pressure according to his or her driving:

#	Recommendations	Vehicle
1	Driving on paved surfaces	PSI 7–8
2	Driving over rough (desert) roads	PSI 6–6.5
3	Minimum pressure	PSI 6–6.5
4	Pressure during storage	PSI 14

Appendix V-Tire Inspection



- Check tires for cuts, cracks, exposed fabric or tire cords or for nails or other objects embedded in the sidewall or tread;
- Check for bulges or swellings in the sidewalls of the tires

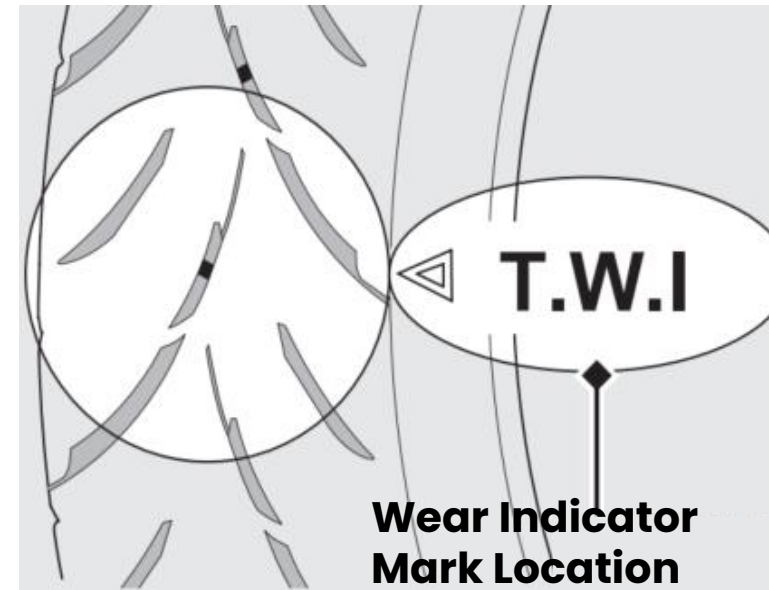

- Check the tread wear indicator markings. If the wear indicators are visible, replace the tire immediately;
- **Minimum tread depth: 2.0 mm**

- Tire parameters:
- Tire specification: AT22×7*10
- Tire type: vacuum tire (all-terrain)
- Maximum load: 115kg (single tire)
- Maximum speed: 130km/h
- Applicable wheel model: J10×7

Caution:

- Riding with severely worn tires will deteriorate the driving performance of the vehicle and may additionally pose an accident hazard;
- Use of tires that have been visibly damaged by external forces may create a risk of an accident;
- Use tires recommended in this manual or equivalent products of the same size, construction, speed rating and load capacity.
- Failure to do so may impair handling and stability and lead to an accident with serious injury or even death.

Appendix VI-Shock Absorber Adjustment

① Rebound adjustment knob

Used to adjust the rebound damping of the shock absorber. Turning left decreases the damping force; turning right increases the damping force.

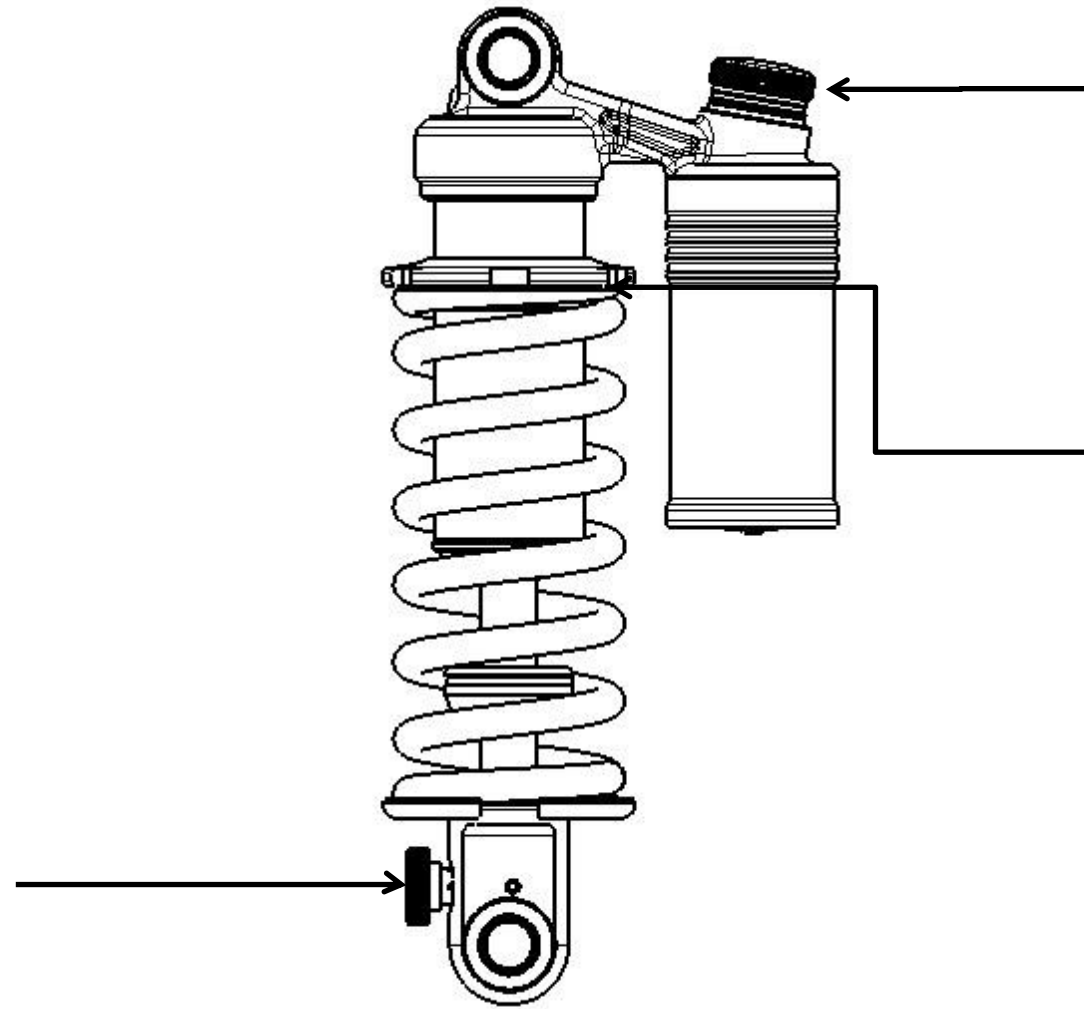

② Compression adjustment knob

Used to adjust the compression damping of the shock absorber. Turning left decreases the damping force; turning right increases the damping force.

③ Adjustment nut

Used to adjust the spring preload.

Appendix VII-Toe Angle Adjustment

When the toe angles of front and rear wheel are not zero, loosen the lock nuts on the tie rods. By rotating the adjustment rods, the length of the steering tie rods can be changed to adjust the wheel toe angle. After adjustment, tighten the two lock nuts.

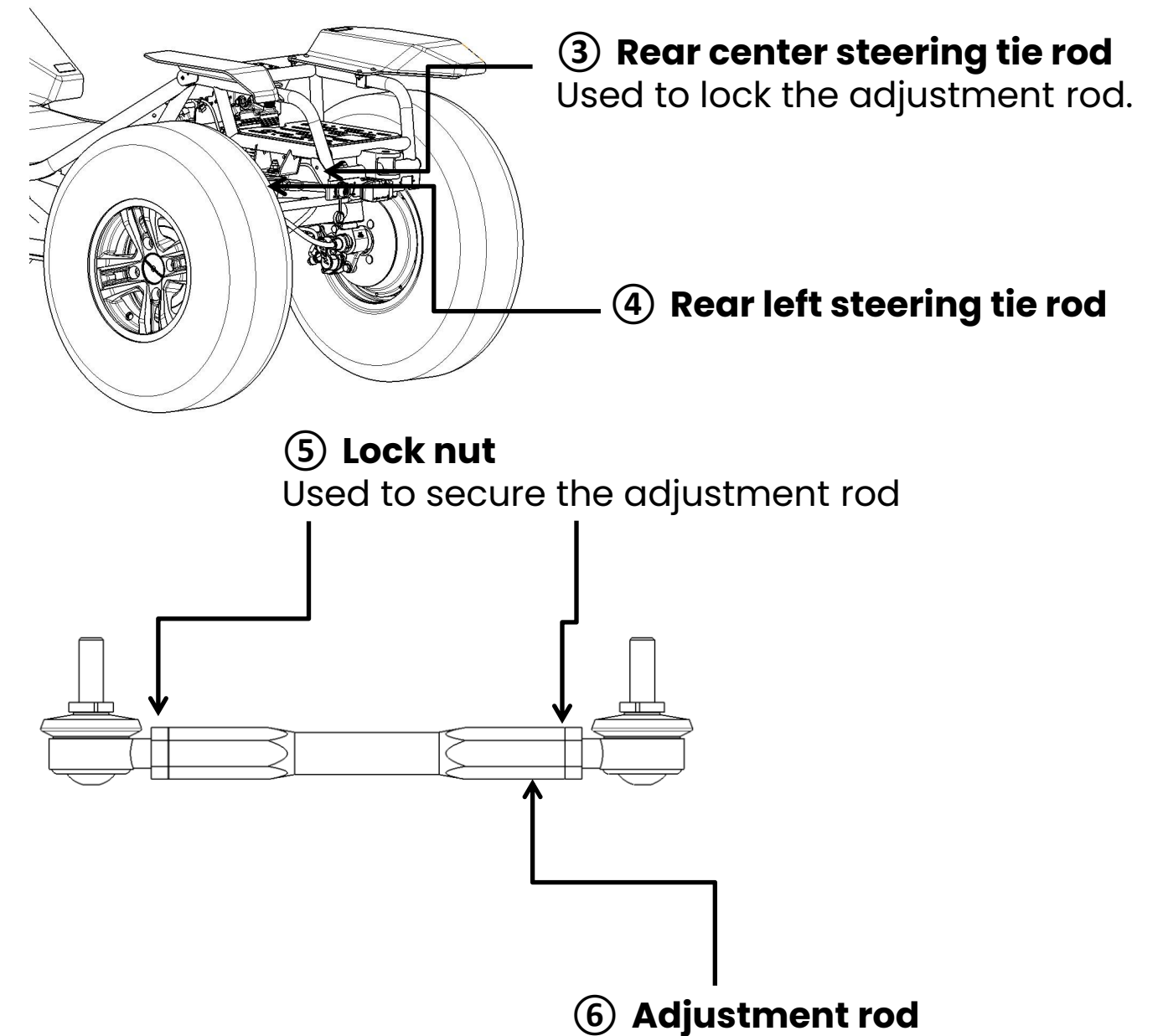
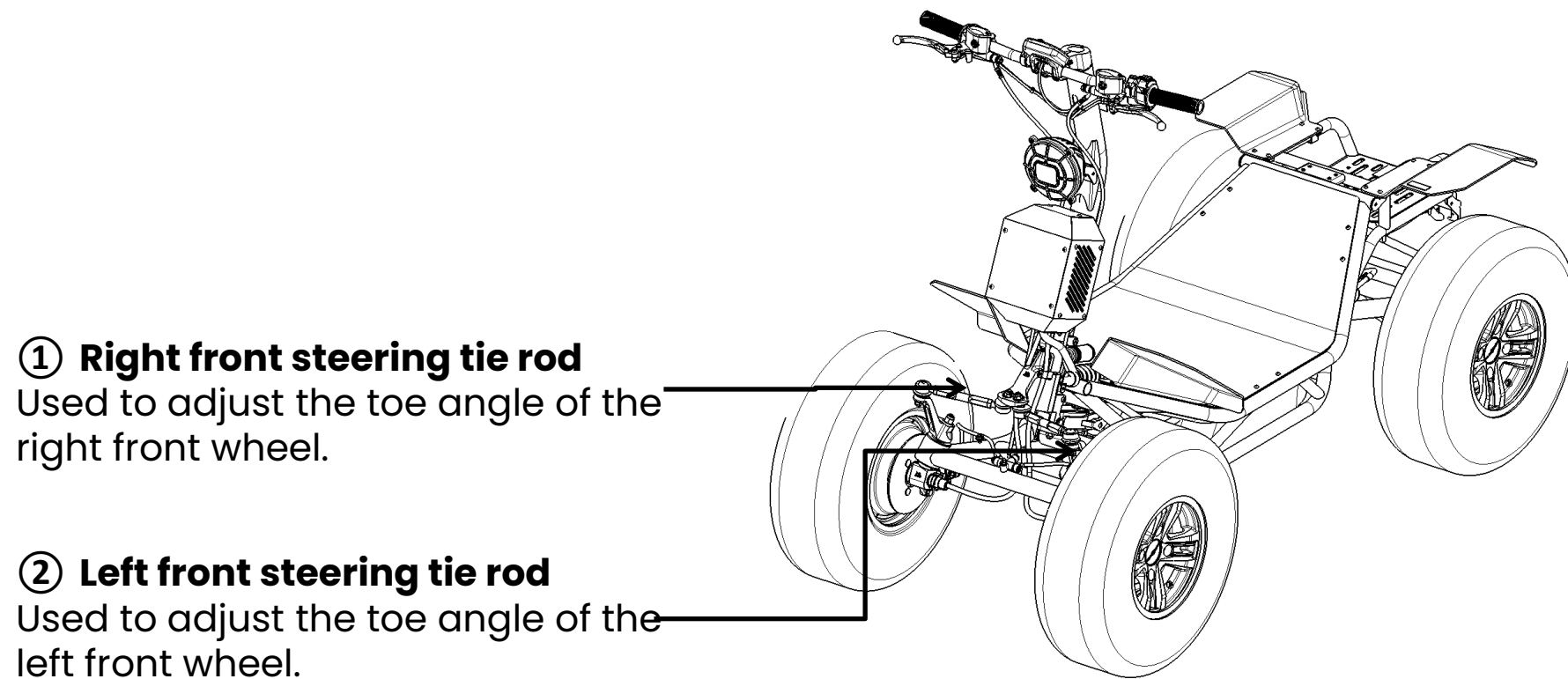



CONTACT US

Email: sales@rjtech-offroad.com

